



UbiBot Wind Direction Sensor UB-WD-N1 3m cable for GS1-S

SKU: UBIWDGS1S
Manufacture Warranty period: 12 months
Country of Origin: China

Descriptions

The wind direction sensor is compact and lightweight, easy to carry and assemble, and the three-cup design concept allows effective access to external environmental information. The body is made of polycarbonate composite material, providing excellent corrosion and erosion resistance and ensuring the instrument is rust-free for long periods of time. The smooth internal bearing system ensures accurate information collection.

It can be used for wind direction measurement in greenhouses, environmental protection, weather stations, ships, docks, farming and other environments.

Features

- RS485 interface, long communication distance.
- High performance imported bearings, low rotation resistance, accurate measurement.
- Polycarbonate shell, high mechanical strength, high hardness, corrosion resistance, can be used for a long time in outdoor.
- Low rotation inertia, sensitive response.
- Standard audio interface design, plug and play.
- Anti-electromagnetic interference.
- Wide voltage input, DC10-30V.
- Standard MODBUS RTU protocol.

Applications

It is widely used in greenhouses, environmental protection, weather stations, ships, docks, plants breeding and other outdoor locations.

Specification

Working Voltage	10~12V DC
Power	≤0.2W
Measuring range	0-359.9°
Accuracy	±1°
Operating temperature:	-20°C~60°C
Working humidity:	0%RH~80%RH
Output signal:	RS485 (Modbus protocol)
Interface Type:	Audio interface
Dimensions:	Base diameter: φ80mm
	Height: 190mm
Cable Length:	3m

Use Case Scenarios

It is widely used in greenhouses, environmental protection, weather stations, ships, docks, plants breeding and other outdoor locations.

Dimensions.

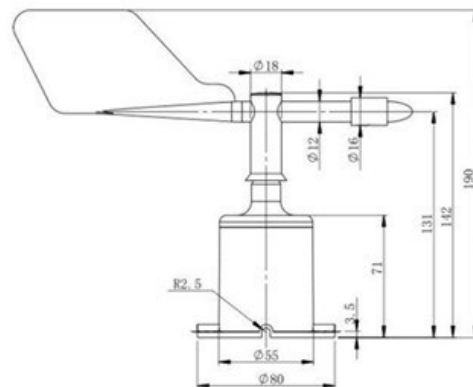

Unit: mm

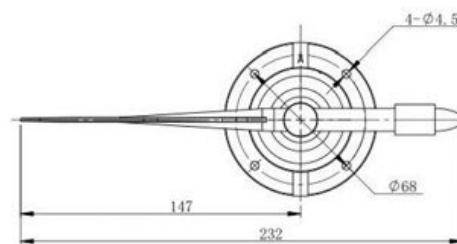

Unit: mm

Mounting Method

It use flange installation. The base plate is $\phi 80\text{mm}$; open four mounting holes with a diameter of $\phi 4.5\text{mm}$ on the circumference of $\phi 68\text{mm}$, fix the sensor on the bracket tightly with bolt, and keep the sensor at the best horizontal level, to ensure the accuracy of wind direction measurement. Make sure the arrow on the sensor points to due north to avoid measurement errors.



Note:

1. Users are not allowed to disassemble the sensor, especially the sensor core, so as to avoid damage to the product.
2. Try to stay away from high-power devices' interfering, to avoid inaccurate measurements, such as frequency converters, motors, etc.
3. Prevent from water, chemical reagents, oil, dust, etc. Do not use the sensor for a long time in dew condensation and extreme temperature environment.
4. GS1 that supporting the sensor must be powered by DC12V power supply.